

**Programming Guide**  
**STANDARD Features Setting**  
( **Version 14 – Dip Switch #5 OFF** )  
(Enter 9023 to check version)

**Platinum 3 & Platinum 3B**  
( For High Traffic Doors *with* Antenna System & RF Tags )

**Pages 2 – 8**

---

**Programming Guide**  
**ENHANCED Features Setting**  
**With Optional Friends & Family Codes**  
( **Version 14 – Dip Switch #5 ON** )  
(Enter 9023 to check version)

**Platinum 3 & Platinum 3B**  
( For High Traffic Doors *with* Antenna System & RF Tags )

**Pages 9 – 15**

**Programming Guide**  
**STANDARD Features Setting**  
**( Version 14 – Dip Switch #5 OFF )**  
(Enter 9023 to check version)

**Platinum 3 & Platinum 3B**  
( For High Traffic Doors *with* Antenna System & RF Tags )

**PLATINUM 3**



**PLATINUM 3B**

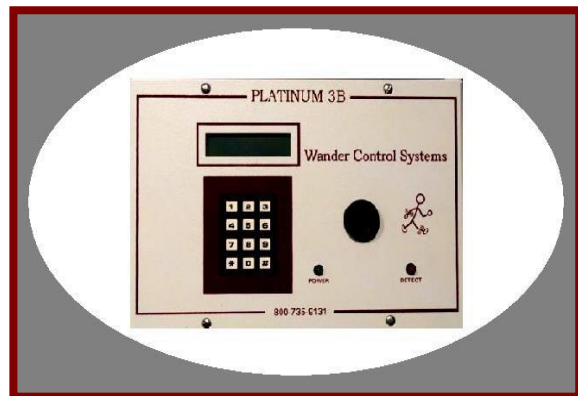

**Wander Control Systems, Inc.**

210 Richlandtown Pike  
Quakertown, PA 18951

Telephone 215-538-1983  
After Hours 407-446-0055

**[www.wandercontrol.com](http://www.wandercontrol.com)**

# **Platinum 3 & Platinum 3B**

## **Operating System (STANDARD Version 14)**

### **Programming Guide**

### **Quick Reference Sheet**

---

- 9001 – Change Employee Escort Time
- 9002 – Change Employee Escort Code
- 9003 – Change Wander Alarm Pattern
- 9006 – Turn ON the Perimeter Alarm and/or Maglock
- 9007 – Turn OFF the Perimeter Alarm and/or Maglock
- 9010 – Change Perimeter Alarm Pattern
- 9011 – Display Last 5 Tag ID Bits Detected
- 9012 – Change Display Time
- 9013 – Set ON Time for Perimeter Alarm and/or Maglock
- 9014 – Set OFF Time for Perimeter Alarm and/or Maglock
- 9015 – Set Maximum Tag ID Bit Detected
- 9016 – Set Minimum Tag ID Bit Detected
- 9017 – Display ON/OFF Times for Perimeter Alarm and/or Maglock
- 9018 – Display Network Address
- 9023 – *Operating System Version Identifier*
- 9029 – Test Mode When Installing or Adjusting Antennas
- 9030 – Escort Time Countdown Chirping Sound
- 9099 – *RESET to Original Factory Settings*

**[www.wandercontrol.com](http://www.wandercontrol.com)**

## Programming Guide for Platinum 3 & 3B Operating Systems (STANDARD Version 14)

---

**PROGRAMMING** - The Platinum 3 and Platinum 3B use simple codes that allow the user to make changes to the operation of the controller.



Commonly Used Programming Code

**W**

Wander Mode Programming Code

**P**

Perimeter Mode Programming Code



### 9001 – Change Escort Time

This function allows you to set the escort time from 1 – 255 seconds.

**Example:** to program an escort time of 45 seconds enter the following:

**9001#45#**



### 9002 – Change Employee Escort Code

Factory programmed escort code is “217.” You may easily change this code to a 1 - 5 digit code. **Do not use the numeral “9” and do not use repeating numerals within the code.**

**Example:** to program a new escort code of “4312” enter the following:

**9002#4312#**



If you change the escort code on the Platinum 3 or Sentry, you must also change the escort code on the opposite side keypad (KP-1 and KP-2).

**W**

### 9003 – Change Wander Alarm Pattern

The factory programmed alarm sound is a steady tone. To change the tone, use the formula to select an option below.

0	steady on (default)
1	on .75 seconds - off .75 seconds
2	on .31 seconds - off .31 seconds
3	on .19 seconds - off .38 seconds
4	on .06 seconds - off .06 seconds
5	on .75 seconds - off .25 seconds
6	on .5 seconds - off .25 seconds
7	on .25 seconds - off .50 seconds
8	on .25 seconds - off .375 seconds
9	alarm off

**Example:** to change from the default steady tone to a pulsing tone such as “5” enter the following: **9003#5#**

**P 9006** – Turn ON the Perimeter Alarm and/or Maglock

This command puts the Platinum Controller directly into the Perimeter Mode until Code 9007 is used to exit perimeter mode.

**Temporarily overrides the 9013 function.**

**P 9007** – Turn OFF the Perimeter Alarm and/or Maglock

This command takes the Platinum Controller out of Perimeter Mode and places it back into Wander Mode.

**Temporarily overrides the 9014 function.**

**After using 9007, recommended to check controller status using 9017 code.**

**P 9010** – Change Perimeter Alarm Pattern

The factory programmed alarm sound is a steady tone. To change the tone, use the formula to select an option below.

0	steady on (default)
1	on .75 seconds - off .75 seconds
2	on .31 seconds - off .31 seconds
3	on .19 seconds - off .38 seconds
4	on .06 seconds - off .06 seconds
5	on .75 seconds - off .25 seconds
6	on .5 seconds - off .25 seconds
7	on .25 seconds - off .50 seconds
8	on .25 seconds - off .375 seconds
9	alarm off

**Example:** to change from the default steady tone to a pulsing tone such as “5” enter the following: **9010#5#**

**9011** – Display Last 5 Tag ID Bits Detected

Press 9011, then \* to see most recent tag. Push \* quickly again for up to 5 tags. Pushing # makes the list go back up to the most recent tag.

**9012** – Change Display Time

The time display in the Platinum system uses a 24 hour or “military” time. It is important to have the time programmed correctly.

**Example:** to change the time to 9:15 PM (21:15) you would enter the following: **9012#2115#**

**P 9013** – Set ON Time for Perimeter Alarm and/or Maglock

This is the time that the control unit would automatically enter Perimeter Mode.

**Example:** to enter the Perimeter Mode every night at 7:00 PM you would enter the following: **9013#1900#**

**P 9014** – Set OFF Time for Perimeter Alarm and/or Maglock

This is the time that the control unit would automatically exit the Perimeter Mode and return to Wander Mode.

**Example:** to exit perimeter mode at 6:00 AM every morning enter the following: **9014#0600#**

**9015** – Set Maximum Tag ID Bit Detected

This is used to set the maximum tag ID that the unit will read (default = 254). The range of tag IDs is 1 – 254.

**Example:** to set the maximum tag ID to 200 you would enter the following: **9015#200#**

**9016** – Set Minimum Tag ID Bit Detected

This is used to set minimum tag ID that the unit will read (default = 1). The range of tag IDs is 1 – 254.

**Example:** to set the maximum tag ID to 23 you would enter the following: **9016#23#**

**P 9017** – Display ON/OFF Times for Perimeter Alarm and/or Maglock**9018** – Display Network Address

This function is for use with data reporting through the RS485 Port.

**9023** – Operating System Version Identifier

This command will display the version number of the installed operating system for 5 seconds.

**9029** – Test Mode When Installing or Adjusting Antennas

In this mode the unit will produce a short beep every time a tag is detected. This is very useful when setting up the receive antenna.

Note: to leave this mode simply enter 9029 again. (9029 toggles mode)

**9030** – Escort Time Countdown Chirping Sound

Allows a chirping sound to be toggled on/off to indicate the control unit is in Escort Mode.



**9099** – RESET to Original Factory Settings

This command will return all functions to the original factory settings.

**NOTE: Removing power from the Controller does not affect any part of the memory in the system except the time on the display.**

**THIS DOCUMENT, OTHER MANUALS, GUIDES, AND SUPPORT MATERIALS CAN BE FOUND ON OUR WEBSITE.**

**Wander Control Systems, Inc.**

210 Richlandtown Pike  
Quakertown, PA 18951

Telephone      215-538-1983  
After Hours    407-446-0055

**[www.wandercontrol.com](http://www.wandercontrol.com)**

# How to Lock Out Unauthorized Code Changes ~ Platinum 3, Platinum 3B, & Sentry

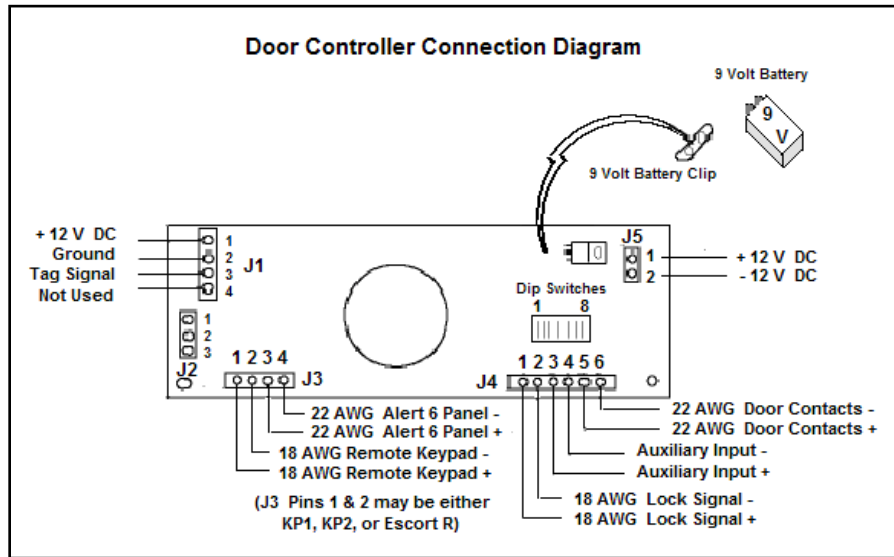

## Procedure

- 1) Set all 9000 Codes on the door controller and optional keypad
- 2) Remove screws from the faceplate of the door controller to access the board pictured above
- 3) Once the 9000 codes are set as desired, turn Dip Switch 3 to the ON position
- 4) Remove the 9 volt battery
- 5) Remove the Power Connection for at least 10 seconds
- 6) Reconnect the Power Supply
- 7) Reinstall the 9 volt battery
- 8) Set the proper time using Code 9012
- 9) Install a short wire jumper on J4 – pins 3 & 4
- 10) Reposition the faceplate with screws onto the backbox

This procedure will prevent accidental, unauthorized, or malicious reprogramming of the '9000 Codes.' The escort codes and access codes will still function properly, but all programming codes known as '9000 Codes' will be disabled.

Please refer to Installation Manuals & Programming Guides for complete information about Platinum 3, Platinum 3B, and Sentry door controllers.

## **Wander Control Systems, Inc.**

210 Richlandtown Pike ♦ Quakertown, PA 18951  
Telephone 215-538-1983 ♦ After Hours 407-446-0055

**[www.wandercontrol.com](http://www.wandercontrol.com)**



# **Programming Guide**

## **ENHANCED Features Setting**

**( Version 14 – Dip Switch #5 ON )**  
(Enter 9023 to check version)

# **Platinum 3 & Platinum 3B**

**( For High Traffic Doors *with* Antenna System & RF Tags )**

### **PLATINUM 3**



### **PLATINUM 3B**

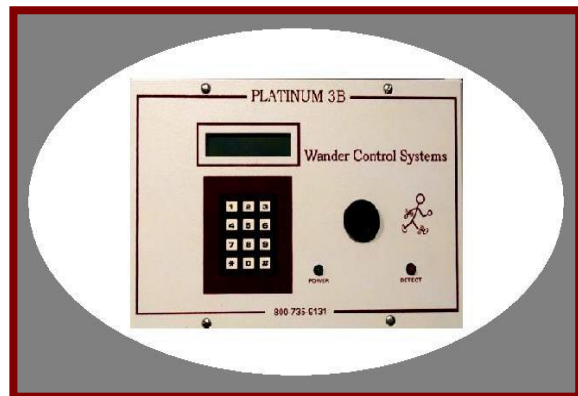

## **Wander Control Systems, Inc.**

210 Richlandtown Pike  
Quakertown, PA 18951

Telephone 215-538-1983  
After Hours 407-446-0055

**[www.wandercontrol.com](http://www.wandercontrol.com)**

# **Platinum 3 & Platinum 3B**

## **Operating System (ENHANCED Version 14)**

### **Programming Guide**

### **Quick Reference Sheet**

---

- 9001 – Change Employee Escort Time
- 9002 – Change Employee Escort Code
- 9003 – Change Alarm Pattern
- 9005 – Change Friends & Family Access Code
- 9006 – Turn ON the Perimeter Alarm and/or Maglock
- 9007 – Turn OFF the Perimeter Alarm and/or Maglock
- 9010 – Change Perimeter Alarm Pattern
- 9011 – Display Last 5 Tag ID Bits Detected
- 9012 – Change Display Time
- 9013 – Set ON Time for Perimeter Alarm and/or Maglock
- 9014 – Set OFF Time for Perimeter Alarm and/or Maglock
- 9015 – Set Maximum Tag ID Bit Detected
- 9016 – Set Minimum Tag ID Bit Detected
- 9017 – Display ON/OFF Times for Perimeter Alarm and/or Maglock
- 9018 – Display Network Address
- 9023 – *Operating System Version Identifier*
- 9029 – Test Mode When Installing or Adjusting Antennas
- 9030 – Escort Time Countdown Chirping Sound
- 9034 – Friends & Family Mode Back-up Wander Alarm
- 9099 – *RESET to Original Factory Settings*

**[www.wandercontrol.com](http://www.wandercontrol.com)**

## Programming Guide for Platinum 3 & 3B Operating Systems (ENHANCED Version 14)

---

**PROGRAMMING** - The Platinum 3 and Platinum 3B use simple codes that allow the user to make changes to the operation of the controller.



Commonly Used Programming Code

**W**

Wander Mode Programming Code

**P**

Perimeter Mode Programming Code



### 9001 – Change Escort Time

This function allows you to set the escort time from 1 – 255 seconds.

**Example:** to program an escort time of 45 seconds enter the following:

**9001#45#**



### 9002 – Change Employee Escort Code

Factory programmed escort code is “217.” You may easily change this code to a 1 - 5 digit code. **Do not use the numeral “9” and do not use repeating numerals within the code.**

**Example:** to program a new escort code of “4312” enter the following:

**9002#4312#**



If you change the escort code on the Platinum 3 or Sentry, you must also change the escort code on the opposite side keypad (KP-1 and KP-2).

**W**

### 9003 – Change Alarm Pattern

The factory programmed alarm sound is a steady tone. To change the tone, use the formula to select an option below.

0	steady on (default)
1	on .75 seconds - off .75 seconds
2	on .31 seconds - off .31 seconds
3	on .19 seconds - off .38 seconds
4	on .06 seconds - off .06 seconds
5	on .75 seconds - off .25 seconds
6	on .5 seconds - off .25 seconds
7	on .25 seconds - off .50 seconds
8	on .25 seconds - off .375 seconds
9	alarm off

**Example:** to change from the default steady tone to a pulsing tone such as “5” enter the following: **9003#5#**

**P 9005** – Change Friends & Family Access Code

Factory programmed escort code is “712.” You may easily change this code to a 1 - 5 digit code. **Do not use the numeral “9” and do not use repeating numerals within the code.**

**Example:** to program a new escort code of “4312” enter the following:  
**9005#4312#**

**P 9006** – Turn ON the Perimeter Alarm and/or Maglock

This command puts the Platinum Controller directly into the Perimeter Mode until Code 9007 is used to exit perimeter mode.

**Temporarily overrides the 9013 function.**

**P 9007** – Turn OFF the Perimeter Alarm and/or Maglock

This command takes the Platinum Controller out of Perimeter Mode and places it back into Wander Mode.

**Temporarily overrides the 9014 function.**

**After using 9007, recommended to check controller status using 9017 code.**

**P 9010** – Change Perimeter Alarm Pattern

The factory programmed alarm sound is a steady tone. To change the tone, use the formula to select an option below.

0	steady on (default)
1	on .75 seconds - off .75 seconds
2	on .31 seconds - off .31 seconds
3	on .19 seconds - off .38 seconds
4	on .06 seconds - off .06 seconds
5	on .75 seconds - off .25 seconds
6	on .5 seconds - off .25 seconds
7	on .25 seconds - off .50 seconds
8	on .25 seconds - off .375 seconds
9	alarm off

**Example:** to change from the default steady tone to a pulsing tone such as “5” enter the following: **9010#5#**

**9011** – Display Last 5 Tag ID Bits Detected

Press 9011, then \* to see most recent tag. Push \* quickly again for up to 5 tags. Pushing # makes the list go back up to the most recent tag.

**9012** – Change Display Time

The time display in the Platinum system uses a 24 hour or “military” time. It is important to have the time programmed correctly.

**Example:** to change the time to 9:15 PM (21:15) you would enter the following: **9012#2115#**

**P 9013** – Set ON Time for Perimeter Alarm and/or Maglock

This is the time that the control unit would automatically enter Perimeter Mode.

**Example:** to enter the Perimeter Mode every night at 7:00 PM you would enter the following: **9013#1900#**

**P 9014** – Set OFF Time for Perimeter Alarm and/or Maglock

This is the time that the control unit would automatically exit the Perimeter Mode and return to Wander Mode.

**Example:** to exit perimeter mode at 6:00 AM every morning enter the following: **9014#0600#**

**9015** – Set Maximum Tag ID Bit Detected

This is used to set the maximum tag ID that the unit will read (default = 254). The range of tag IDs is 1 – 254.

**Example:** to set the maximum tag ID to 200 you would enter the following: **9015#200#**

**9016** – Set Minimum Tag ID Bit Detected

This is used to set minimum tag ID that the unit will read (default = 1). The range of tag IDs is 1 – 254.

**Example:** to set the maximum tag ID to 23 you would enter the following: **9016#23#**

**P 9017** – Display ON/OFF Times for Perimeter Alarm and/or Maglock**9018** – Display Network Address

This function is for use with data reporting through the RS485 Port.

**9023** – Operating System Version Identifier

This command will display the version number of the installed operating system for 5 seconds.

**9029 – Test Mode When Installing or Adjusting Antennas**

In this mode the unit will produce a short beep every time a tag is detected. This is very useful when setting up the receive antenna.

Note: to leave this mode simply enter 9029 again. (9029 toggles mode)

**9030 – Escort Time Countdown Chirping Sound**

Allows a chirping sound to be toggled on/off to indicate the control unit is in Escort Mode.

**9034 – Friends & Family Mode Back-up Wander Alarm**

Turns on/off a secondary alarm when the controller is set to Family Mode and a tag is in the active field. Alarm will time-out after 10 seconds.



**9099 – RESET to Original Factory Settings**

This command will return all functions to the original factory settings.

**NOTE: Removing power from the Controller does not affect any part of the memory in the system except the time on the display.**

**THIS DOCUMENT, OTHER MANUALS, GUIDES, AND SUPPORT MATERIALS CAN BE FOUND ON OUR WEBSITE.**

**Wander Control Systems, Inc.**

210 Richlandtown Pike  
Quakertown, PA 18951

Telephone 215-538-1983  
After Hours 407-446-0055

**[www.wandercontrol.com](http://www.wandercontrol.com)**

## How to Lock Out Unauthorized Code Changes ~ Platinum 3, Platinum 3B, & Sentry

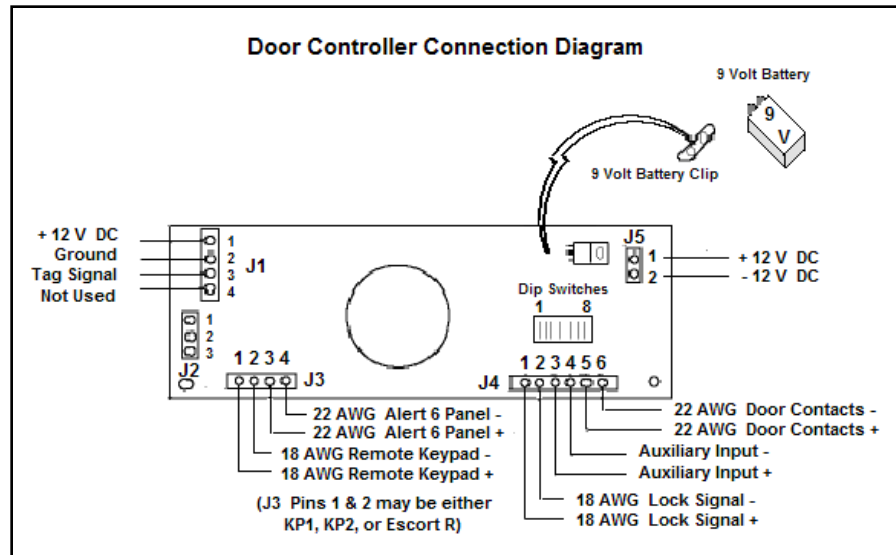

### Procedure

- 1) Set all 9000 Codes on the door controller and optional keypad
- 2) Remove screws from the faceplate of the door controller to access the board pictured above
- 3) Once the 9000 codes are set as desired, turn Dip Switch 3 to the ON position
- 4) Remove the 9 volt battery
- 5) Remove the Power Connection for at least 10 seconds
- 6) Reconnect the Power Supply
- 7) Reinstall the 9 volt battery
- 8) Set the proper time using Code 9012
- 9) Install a short wire jumper on J4 – pins 3 & 4
- 10) Reposition the faceplate with screws onto the backbox

This procedure will prevent accidental, unauthorized, or malicious reprogramming of the '9000 Codes.' The escort codes and access codes will still function properly, but all programming codes known as '9000 Codes' will be disabled.

Please refer to Installation Manuals & Programming Guides for complete information about Platinum 3, Platinum 3B, and Sentry door controllers.

### **Wander Control Systems, Inc.**

210 Richlandtown Pike ♦ Quakertown, PA 18951  
Telephone 215-538-1983 ♦ After Hours 407-446-0055

**[www.wandercontrol.com](http://www.wandercontrol.com)**